



MK-A35

35t Underground Haulage Truck

Main Features

- 35.000 kg payload capacity
- Compact, simple and powerful design
- Hard rock and tunneling applications
- Great power to weight ratio
- Extremely robust GHH frame and system design resulting in lowest operating cost
- EU Stage 5 incl. particle filter
- ROPS/FOPS certified Bi-directional cabin saves time and increases productivity
- Dump Box range from 13 m³ up to 23 m³
- Proven technology
- Optimal traction and higher driving comfort thanks to **Oscillating articulation and front axle suspension system**

Technical Specification

MAIN DIMENSIONS

Length	10 835 mm
Width (at body)	3 100 - 3 500 mm
Height, laden (at body)	2 346 - 2 850 mm
Height, laden (above cabin)	2 897 mm
Std. body capacity (SAE heaped)	20 m ³
Dump Box range	13.0 - 23.0 m ³
Outer turn radius	9 630 mm
Inner turn radius	5 330 mm

ENGINE

Manufacturer	Mercedes
Type	OM470
Design	Water cooled diesel engine
Power output	320 kW / 1700 min ⁻¹
Air intake system	Dry air filter
Exhaust system	SCR, DPF*
Starter power / voltage	7 kW / 24 V
Alternator current	100 A / 28 V
Emission standard	EU Stage V / Tier 4

*requires ultra low sulphur diesel

ENGINE OPTION

Mercedes OM 470, 300 kW, EPA Tier3, silencer and catalyst

FUEL

Fuel Tank capacity	475 l	S	O
--------------------	-------	---	---

BRAKES

Service / Parking / Emergency	SAHR	S	O
Electric brake release pump			
Neutral brake			

WEIGHTS*

Operating weight	31650 kg
Payload capacity	35000 kg
Front axle, empty	22 230 kg
Rear axle, empty	9 420 kg
Front axle, loaded	29 400 kg
Rear axle, loaded	37 250 kg
Total loaded weight	66 650 kg

*Weight is dependent on the selected options

SPEEDS FORWARD & LOADED

1st gear	5.6 km/h
2nd gear	9.9 km/h
3rd gear	17.4 km/h
4th gear	31.0 km/h
Max admissible gradient	25%

DUMP BOX MOTION TIMES

Discharging time	21 sec
Dumping angel	59°



CONVERTER

Brand / Type	Dana CL 8 000 with lock up	S	O
--------------	----------------------------	---	---

AXLES

Brand / Type	Kessler D102	S	O
--------------	--------------	---	---

TRANSMISSION

Power shift transmission with 4 forward and 4 reverse gears	Dana 6 000 Series	S	O
Gear box protection			
Block out Gears			

S Standard Equipment **O** Optional Equipment



MK-A35

GHH

SOLID AS A ROCK



MK-A35

GHH
SOLID AS A ROCK

MK-A35

GHH Fahrzeuge GmbH • ghh-fahrzeuge.de • info@ghh-fahrzeuge.de • +49 209-38907-0

*Changes may apply without prior notice. Featured machines in photos may include variations / additional equipment

Technical Specification

FRAME S O

Front axle suspension

Articulation oscillation joint for maximum drive comfort and excellent ground contact

3pt. Access

TYRES S O

Tyre Size 26,5 - 25

Rim Size 22.00-25/3.0

OPERATORS CABIN S O

ROPS approved according EN ISO 3471

FOPS approved according to EN ISO 3449v

Closed cabin incl. Windows and isolation

Seat Grammer 3pt. belt

Ventilation for cabin

Sliding window

12V converter in cabin

Heating

Air conditioning

Inclinometers

Audio Media Player



SERVICE / MAINTENANCE S O

Centralized lubrication points

Automated central lubrication

ELECTRICAL SYSTEM S O

Voltage 24 V

Batteries 2x12 V /180Ah

Lockable main switch

Jump Start interface

3x Emergency stop button

Data-Logger

Data-Logger and WiFi



LIGHTS S O

Front lights LED

Rear lights LED

Turn signals

Brake lights

Rotating beacon

Additional Working lights LED

HYDRAULIC SYSTEM S O

System Pressure 175 bar

Hydraulic tank 430 l

Number of steering cylinders 2

Number of dump cylinders 1

Emergency Steering

S Standard Equipment **O** Optional Equipment

Technical Specification

SAFETY FEATURES

S O

Reverse alarm
Emergency stop push buttons according to EN ISO 13850
Frame articulation locking device
Mechanical dump box locking device
Wheel chocks
Mirrors
Rear view camera
Side view camera
Dump Box Interlocking incl. warning signal

FIRE SAFETY

S O

Fire extinguisher	
Additional fire extinguisher	
Fire suppression system	manual
Fire suppression system	automatic

OTHERS

S O

EU certified (CE)
Toolbox
Service manuals in paper

GRADE PERFORMANCE EMPTY

Mercedes OM470 Stage V

Grade [%]	0	5	10,0	14,3	16,6	20
Ratio []		1:20	1:10	1:7	1:6	1:5
1st gear [km/h]	5,6	5,5	5,5	5,5	5,5	5,5
2nd gear [km/h]	9,9	9,9	9,8	9,6	9,6	9,5
3rd gear [km/h]	17,6	17,2	16,9	15,4	13,4	
4th gear [km/h]	31,2	29,9				

GRADE PERFORMANCE LOADED

Mercedes OM470 Stage V

Grade [%]	0	5	10	14,3	16,6	20
Ratio [] <small>GHH</small>		1:20	1:10	1:7	1:6	1:5
1st gear [km/h]	5,6	5,5	5,4	5,3	5,3	5,2
2nd gear [km/h]	9,9	9,7	9,4	7,2		
3rd gear [km/h]	17,6	16,5				
4th gear [km/h]	31,0					



S Standard Equipment

O Optional Equipment

MK-A35

GHH Fahrzeuge GmbH • ghh-fahrzeuge.de • info@ghh-fahrzeuge.de • +49 209-38907-0

*Changes may apply without prior notice. Featured machines in photos may include variations / additional equipment

Dimensions

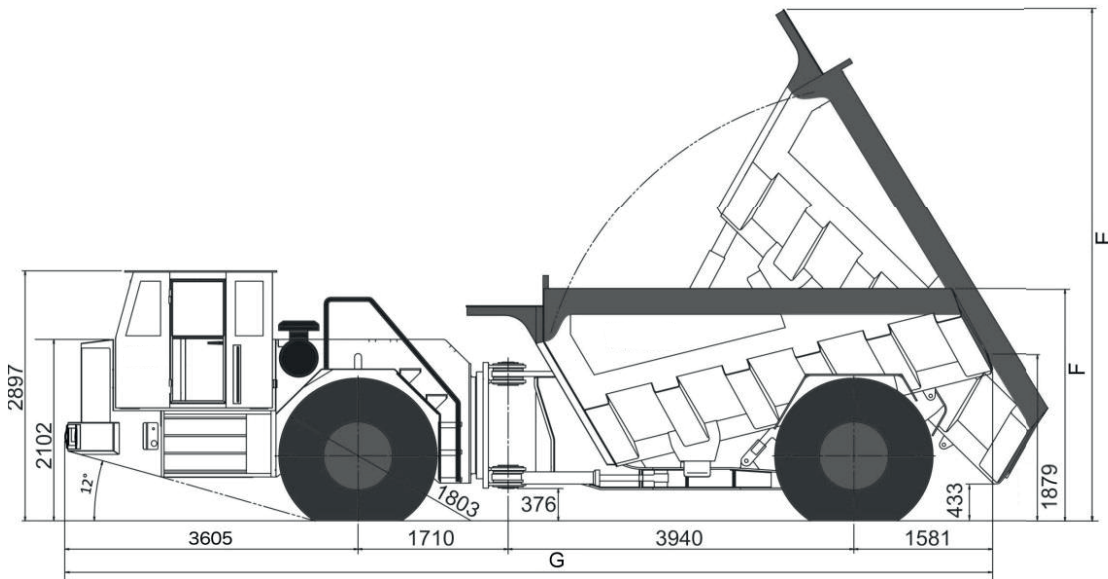
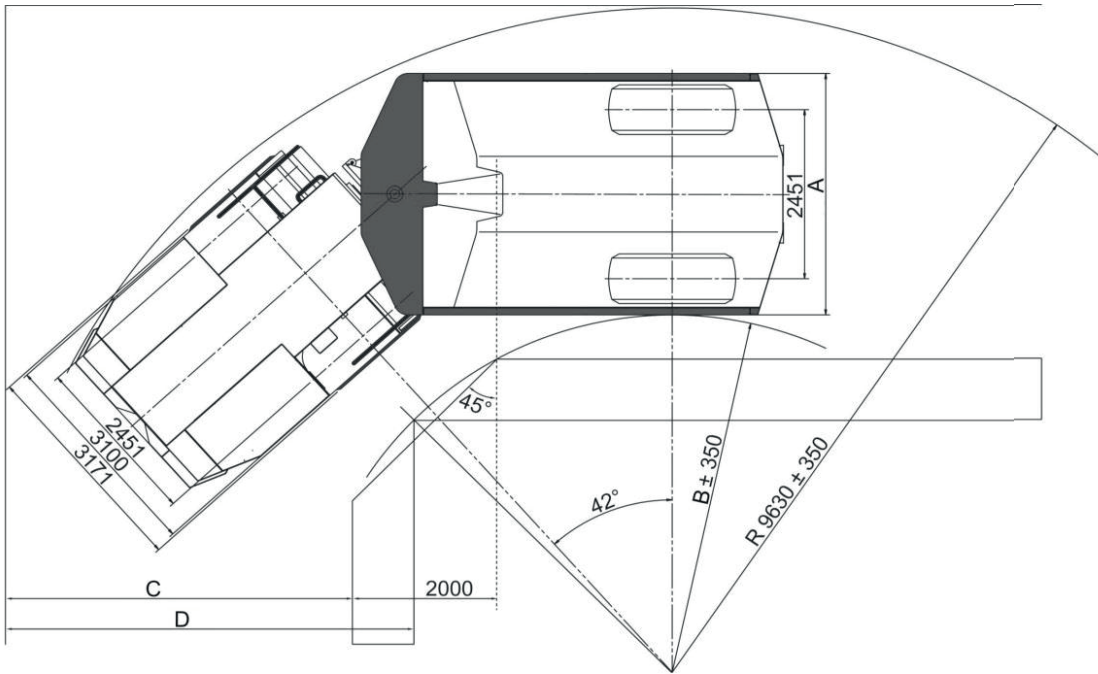

DUMP BOXES*

	Dumping optimized				Tailgate	Low Profile	
Volume [m ³]	13	15	20	23	17,5	17	21
Material density [t/m ³]	2,7	2,1	1,75	1,5	2	2	1,7
Height dump box [mm]	2500	2700	2700	2700	2700	2350	2300
Width dump box [mm]	3200	3200	3200	3500	3360	3200	3500
Inner Turning Radius B [mm]	5330	5330	5330	5180	5410	5330	5180
Gallery width D [mm]	5860	5860	5860	5970	5960	5860	5970
Dump Height E [mm]	5960	5960	5960	6050	5960	5860	5860
Length G [mm]	10840	10020	10840	10840	10120	10720	10940

*further variants on request



GHH

SOLID AS A ROCK

GHH Fahrzeuge GmbH
Emscherstr. 53
45891 Gelsenkirchen

Tel: +49 (0) 209 38907-0
Fax: +49 (0) 209 38907-109

E-Mail: info@ghh-fahrzeuge.de
Web: www.ghh-fahrzeuge.de